

**ROLL CLAMPS
CONCRETE PIPE CLAMPS**

S18

Roll clamps are intended for handling cylindrical goods.

Paper roll clamps operate with one long hydraulically adjustable arm and one short adjustable arm. All clamps have a rotation range of 360° continuous in both directions.

The contact pads of the arms are serially coated with corundum. There are different types of coating available.

Concrete pipe clamps operate with one long hydraulically adjustable arm and one short manually adjustable arm. The rotation range of 360° is continuous in both directions. All clamps are serially equipped with rubber coated contact pads.

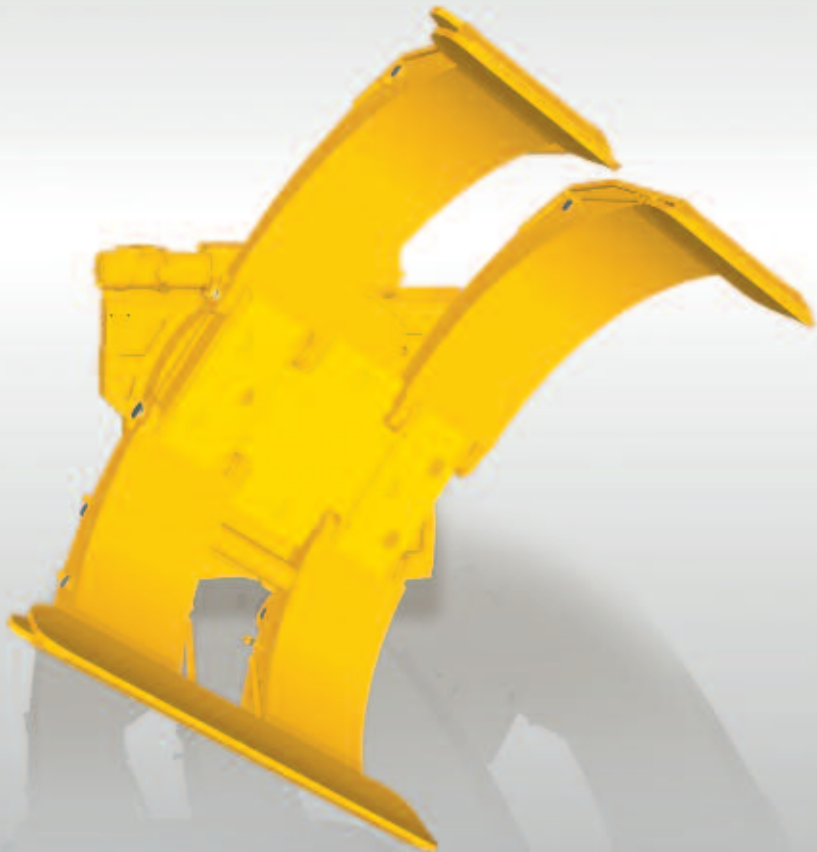

S18

Roll Clamps (Paper Roll Clamps)

2 hydraulic functions

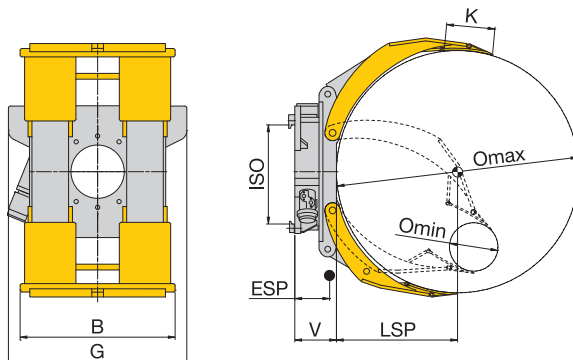

Rotation range 360° · Short arm manually adjustable

Model	Load capacity	LC (LSP)	Roll diameter Omin-Omax	ISO	B	K	G	V	CoG (ESP)	Weight	Price	Surcharge for short hydraulic arm
	kg											
S 18 - RK 13-360°	1300	550	250-1100	2	720	200	900	205	250	470	17,105.-	1,000.-
	1100	650	250-1300							280	490	17,780.-
S 18 - RK 16-360°	1600	650	250-1300	2	720	200	900	210	290	550	18,460.-	1,085.-
	1350	750	250-1500							320	590	19,250.-
S 18 - RK 20-360°	2000	650	250-1300	3	820	230	1080	220	305	650	20,055.-	1,210.-
	1600	800	250-1600							350	710	20,825.-
S 18 - RK 23-360°	2300	650	250-1300	3	820	230	1080	225	315	690	20,490.-	1,210.-
	1850	800	250-1600							360	750	21,255.-
S 18 - RK 25-360°	2500	700	250-1400	3	820	230	1080	230	305	740	23,680.-	1,390.-
	2150	800	250-1600							335	780	24,405.-
S 18 - RK 30-360°	3000	750	250-1500	3	1000	250	1080	250	355	1010	26,145.-	1,450.-
	2500	900	250-1800							410	1090	26,965.-
S 18 - RK 35-360°	3500	750	250-1500	4	1000	250	1220	260	315	1200	28,260.-	1,525.-
	2900	900	250-1800							365	1280	29,075.-
S 18 - RK 40-360°	4000	900	350-1800	4	1000	250	1200	285	365	1510	36,740.-	1,735.-
	3400	1050	350-2100							390	1630	37,590.-
S 18 - RK 50-360°	5000	950	400-1900	4	1200	280	1200	295	395	1840	39,155.-	1,955.-
	4500	1050	400-2100							410	1890	39,640.-
S 18 - RK 60-360°	6000	1000	450-2000	4	1200	280	1200	300	395	1960	43,075.-	2,260.-
	5000	1200	450-2400							445	2150	43,965.-

- Contact pads oscillating, incl. corundum coating.
- Surcharge for PU coating (not for tissue clamps) € 1,210.-
- Other coatings on request.
- Surcharge for tissue clamping system up to RK 16 € 1,315.-
- Surcharge for tissue clamping system up to RK 25 € 1,420.-
- Surcharge for tissue clamping system up to RK 40 € 1,525.-

- Surcharge for two-roll clamping system € 1,180.-
- Surcharge for adjustable pressure relief valve € 320.-
- Surcharge for pressure gauge € 120.-
- Other clamping ranges on request.
- Separate sideshift on request.
- Version of tire clamp on request.

S18



Paper roll clamp



Tire clamp

Standard paper roll clamps are provided with a long hydraulically adjustable arm as well as a short, manually adjustable arm. If big and small rolls have to be handled in turns, we recommend one short, hydraulic arm. The simultaneous handling of two rolls with different diameters requires the two-roll clamp system (split arm).

Standard values for residual load capacity of lift trucks**

Roll Clamps	S 18 -	RK 13 -360°	RK 16 -360°	RK 16 -360°	RK 20 -360°	RK 23 -360°	RK 25 -360°	RK 30 -360°	RK 35 -360°	RK 40 -360°
Load capacity lift truck	kg	1500	2000	2500	3000	3500	4000	5000/500	5000	6000
X*	mm	350	450	450	450	500	500	500	560	560
LC (LSP) = 550 mm	kg	1000								
LC (LSP) = 650 mm	kg	890	1270	1650	1950	2340				
LC (LSP) = 700 mm	kg						2580			
LC (LSP) = 750 mm	kg		1150	1500				3000	3320	
LC (LSP) = 800 mm	kg				1690	2050	2370			
LC (LSP) = 900 mm	kg							2640	2940	3500
LC (LSP) = 1050 mm	kg									3120

** The load capacity applies to lifting heights up to 3300 mm; specifications for greater lifting heights on request.

* Assumed dimensions



Roll clamp for wire coils



Tilting concrete pipe clamps

Concrete Pipe Clamps

2 hydraulic functions

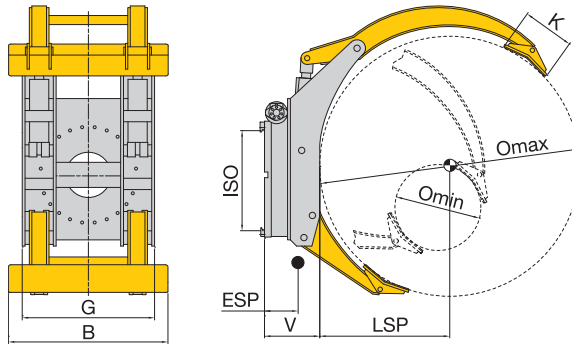

Rotation range 360° · One long arm, hydraulically adjustable · One short arm, manually adjustable

Model	Load capacity	Roll diameter Omin-Omax	ISO	B	K	G	V	CoG (ESP)	Weight	Price	Surcharge per 100 mm add. clamping range	Surcharge for short hydraulic arm
	kg	mm		mm	mm	mm	mm	mm				
S 18 - BRK 25-360°	2500	400-1300	3	1300	350	1250	235	290	1000	26,975.-	330.-	1,390.-
S 18 - BRK 35-360°	3500	400-1500	4	1300	350	1250	300	340	1350	31,240.-	380.-	1,525.-
S 18 - BRK 50-360°	5000	500-1580	4	1400	450	1250	380	400	1750			
S 18 - BRK 60-360°	6000	760-1940	4/Pint.	1400	450	1250	450	450	2500	On request	On request	On request
S 18 - BRK 80-360°	8000	760-2100	4/Pint.	1400	450	1280	485	480	3000			
S 18 - BRK 110-360°	11000	760-2500	Pint.	1400	450	1280	505	555	4350			

- Contact pads articulating, incl. rubber coating.
- Surcharge for adjustable pressure relief valve € 320.-
- Surcharge for pressure gauge € 120.-

S18

Standard values for residual load capacity of lift trucks**

Concrete Pipe Clamps	S 18 -	BRK 25 -360°	BRK 25 -360°	BRK 35 -360°	BRK 35 -360°	BRK 50 -360°	BRK 60 -360°	BRK 60 -360°	BRK 80 -360°	BRK 110 -360°
Load capacity lift truck	kg	3500	4000	5000	6000	8000	10000	12000	16000	20000
X*	mm	500	500	560	560	650	750	800	850	950
LC (LSP) = 650 mm	kg	2150	2550							
LC (LSP) = 750 mm	kg			3150	(3800)					
LC (LSP) = 800 mm	kg					4850				
LC (LSP) = 950 mm	kg						5350	(6600)		
LC (LSP) = 1100 mm	kg								8650	
LC (LSP) = 1250 mm	kg									10100

** The load capacity applies to lifting heights up to 3300 mm; specifications for greater lifting heights on request.

* Assumed dimensions

- For greater load centers, where the lift truck has a higher residual load capacity than the attachment, those values, upon the exceedance of which the attachment would be overloaded, are indicated in brackets ().